

Development and production
of laser and sorting systems

IL 2000 Wafer Marking System



The wafer marking system is controlled by a 19" industrial PC. The powerful Windows™ based software package includes user friendly operator and engineer interface along with sophisticated diagnostic features for maintenance and service personal. Software options include wafer sorting and SECS/GEM host interface. Customized software solutions are available upon request.

The Innolas IL 2000 series laser system is designed to mark various wafer materials with diameters ranging from 2" to 200mm.

Different laser types and setups are available to achieve optimum process results for various materials such as Si, GaAs, Ge, SiC, GaP, InP, Sapphire, Quartz and others.

A deep or debree free marking process is available. Our application engineers are happy to help you with the best process setup.



Development and production of laser and sorting systems

Technical Specifications IL 2000 Series

HANDLING SYSTEM

Wafer sizes:	2", 2.25", 3", 3.25" and 100, 125, 150, 200mm
Wafer transfer:	Robot - double end effector
Wafer alignment:	Opto mechanical aligner
Wafer handling:	Vacuum or edge grip
Number of stations:	4 stations (input / output)
Throughput:	220 wafers/hr (SEMI M13-88 without reading)

LASER AND OPTICS

Laser type:	Nd:YAG 1064nm, 532nm and 355nm (diode pumped) Nd:YAG 1064nm (lamp pumped) Others on request
Laser class:	Class 1 (Class 4 with open cabinet / service access)
Beam expansion:	Two lens system
Focus lens:	F-Theta objective
Galvo head:	Digitally controlled (field: 110x110mm)
Laser stability:	+/- 1% peek to peek

MARKING

Fonts:	Dot Matrix (SEMI 5x9, 10x18, 15x23 and 9x17) Barcode (SEMI 412, IBM 412) 2D Code (SEMI T7) Engrave Mode (optional)
Checksum:	SEMI, IBM, customized (optional)
Serialization:	Numeric, alphanumeric, IBM (ascending or descending)
Text position:	Adjustable in X and Y direction
Repeatability:	+/- 80µm in X and Y direction
Marking Depth:	0.1µm - 100µm (depending on material type and process setup)

STANDARD OPTIONS

- Reading system for wafer front and / or backside
- Auto laser power controller
- Barcode hand scanner
- Process viewing window with laser safety glass (100x200mm)
- Motorized auto zoom (3 lens system)
- SECS/GEM host software
- Service area control system at backside of machine
- Wafer thickness measurement

FACILITY REQUIREMENTS

Electrical:	400V AC / 3P / N / PE / 50Hz / 16A 208V AC / 3P / N / PE / 60Hz / 25A 208V AC / 2P / PE / 60Hz / 30A
Communication:	Ethernet RJ45 connector
Vacuum:	-800mbar (23.6Hg) - Festo 8mm OD connection
Exhaust:	75m ³ /hr (44.1ft ³ /min) - 50mm ID connection
Weight:	1000kg (2205 lb) depending on options
For lamp pumped laser only:	
Cooling water:	5.5l/min @ 15°C (1.5gal/hr @ 59°F)
Water pressure:	min. 2bar (29psi)

CERTIFICATIONS

- CDRH accession # 0010530
- CE certified

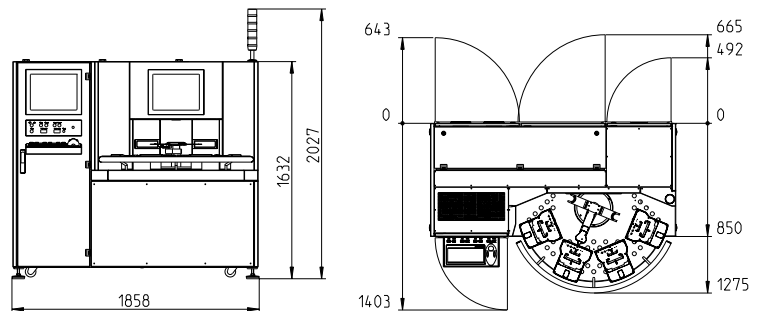

Dimensions in mm